

Clamshell Bucket with exchangeable shells 13 - 18t C18VE

Clamshell Bucket with exchangeable shells and vertical cylinders for excavators from 13t to 18t operating weight – through quick and easy exchange of shells, the C18VE is ideal for different applications, for excavation operations, landscaping, trench digging, handling of logs and more. The shells can be changed in less than four minutes.

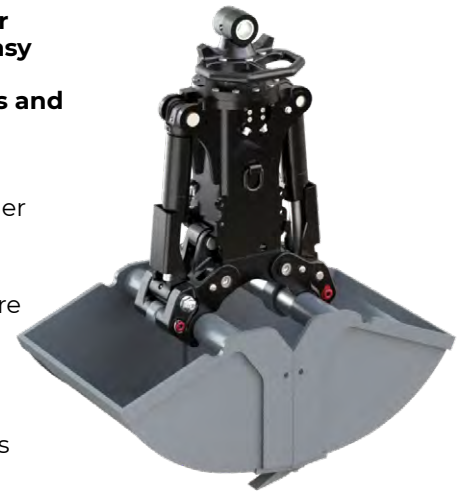

- ▶ **Economic solution** as only the shells have to be exchanged for another application – bucket carrier, hydraulic cylinder and bearings are integrated into the unit.
- ▶ **Long life** is ensured due to the use of 500 HB steel in the manufacture of cutting edges.
- ▶ **Reduced wear** resulting from generously dimensioned bearing system.
- ▶ **Excellent digging characteristics** are the result of high closing forces (42 kN at 35 MPa operating pressure).

Clamshell Bucket C18VE

Type	Width E (mm)	Opening A (mm)	Height C max.(mm)	Length F (mm)	Volume (liter)	Number of teeth	Weight (kg)	Load capacity (kg)
C18VE-33	335	1650	1595	1360	125	3	590	4500
C18VE-40	400	1650	1595	1360	160	3	605	4500
C18VE-50	500	1650	1595	1360	200	5	630	4500
C18VE-60	600	1650	1595	1360	245	5	655	4500
C18VE-80	800	1650	1595	1360	330	9	705	4500
C18VE-100	1000	1650	1595	1360	415	9	755	4500

Package consists of: clamshell bucket, bolt-on teeth, **KINSHOFER** rotator with hose guard, 2 weld-on eyes, shell exchange aid kit and non-return valve

KINSHOFER Rotator

Continuous rotation and two oil passages. Overload protection is ensured by pressure relief valves.

Type	Upper connection (width x pin-Ø) (mm)	Torque (Nm)	Bending moment max. (Nm)
KM 10 F275-60	125 x 60	1500	14000

Accessories

Type	Description
KM 501 13t-25t	upper suspension without pendulum damper
KM 511 13t-25t	upper suspension with pendulum damper
KM 510 13t-25t	single pendulum damper
KSW10 cardanic	adapter for system L-Lock KMS10L/KHS10L incl. cardan link excl. pendulum damper – up to 19t
KSW21/25 cardanic	adapter for system L-Lock KMS21/25L / KHS21/25L incl. cardan link excl. pendulum damper – up to 40t
KM 680 C18VE	scraper

Requirements of carrier machine

Operating pressure (open/close):	max. 35 MPa (350 bar)
Recommended pump capacity (open/close):	75 - max. 150 l/min
Operating pressure (rotate):	max. 32 MPa (320 bar)
Recommended pump capacity (rotate):	20 - max. 50 l/min

Technical drawing

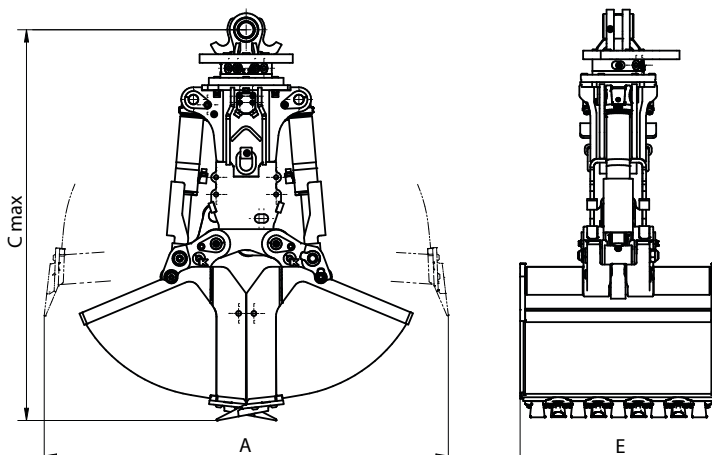

Exchangeable Shells for C18VE

Exchangeable shells for C18VE

Shells are interchangeable and available in all widths. Rapid exchange with shell stand and pin exchange tool.

Type	Width (mm)	Opening (mm)	Height complete (mm)	Volume (liter)	Number of teeth	Weight shells (kg)	Loading capacity (kg)	Closing force (kN)
------	---------------	-----------------	----------------------------	-------------------	--------------------	--------------------------	-----------------------------	--------------------------

Clamshell Bucket

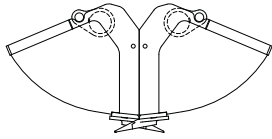

C18VE-33S	335	1535	1595	125	3	160	4500	42
C18VE-40S	400	1535	1595	160	3	180	4500	42
C18VE-50S	500	1535	1595	200	5	195	4500	42
C18VE-60S	600	1535	1595	245	5	225	4500	42
C18VE-80S	800	1535	1595	330	9	275	4500	42
C18VE-100S	1000	1535	1595	415	9	325	4500	42

Excavating Grab

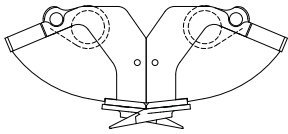

C18VE-33S EG	335	1205	1430	90	3	125	4500	57
C18VE-40S EG	400	1120	1385	55	3	130	4500	60
C18VE-80S EG	800	820	1380	100	9	185	4500	69

Pipe Grab

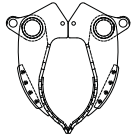

C18VE-83S PG	830	Ø100 - Ø600	1625	Ø600 mm		295*	4500	41
---------------------	-----	-------------	------	---------	--	------	------	----

*incl. support

Well Shaft Grab



C18VE-97S WSG	Ø970	970	1410	110	5	170	4500	65
----------------------	------	-----	------	-----	---	-----	------	----

note: larger shells available on request

Hay and Forestry Grab

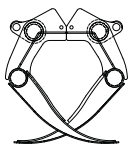

A18VE-95S	955	1830	1685	400		340	4500	41
A18VE-122S	1220	1835	1725	600		275	4500	32

Rock Grab

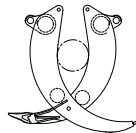

R18VE-49S	490	1850	1820	0,50 m ²		195	4500	33
------------------	-----	------	------	---------------------	--	-----	------	----

Timber Grab

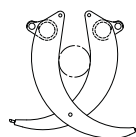

T18VE-49S-0,5	490	1830	1825	0,50 m ²		200	4500	30
T18VE-49S-0,6	490	1975	1905	0,60 m ²		220	4500	33

Rail Tines

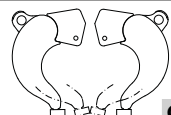

C18VE-50S RG	500	1250	1400	-		130	4500	44
---------------------	-----	------	------	---	--	-----	------	----

Package consists of: shells, teeth (for clamshell bucket, excavating and well shaft grab), shell exchange aid kit and pin extraction tool

Note: special shells on request